

RALF – At a glance

Bioengineering RALF essentials

General

- Autoclavable small benchtop glass reactor
- Versatile reactor system for numerous different applications
- Single as well as multiple systems
- Wide variety of options available
- Installation, training and IQ/OQ service package available

Bioengineering RALF Basic for microbial cultivation

- Single wall vessel with heating pad and cooling finger
- 1 gas channel, pulsed
- 2 fixed speed peristaltic pumps
- With agitation control, temperature control, pH control and DO control
- Incl. BioSCADA RALF for complete process automation and data acquisition, analysis and export

Bioengineering RALF Basic for cell culture

- Single wall vessel with heating pad and cooling finger
- 3 gas channels, pulsed
- 2 fixed speed peristaltic pumps
- With agitation control, temperature control, pH control and DO control
- Incl. BioSCADA RALF for complete process automation and data acquisition, analysis and export

Bioengineering RALF Advanced for microbial cultivation

- Single wall vessel with perfused baffles and heating circuit
- 1 gas channel, pulsed
- 2 fixed and 1 variable speed peristaltic pumps
- With agitation control, temperature control, pH control, DO control and foam/level control
- Incl. BioSCADA RALF for complete process automation and data acquisition, analysis and export

Bioengineering RALF Advanced for cell culture

- Double wall vessel with heating circuit
- 3 gas channels, pulsed
- 2 fixed and 1 variable speed peristaltic pumps
- With agitation control, temperature control, pH control, DO control and foam/level control
- Incl. BioSCADA RALF for complete process automation and data acquisition, analysis and export

Overview

Standard models	RALF for microbial cultivation		RALF for cell culture	
	RALF Basic	RALF Advanced	RALF Basic	RALF Advanced
Total volume [L]	2 3.7 5 6.7			
Geometry D _i :H _i 2 L 3.7 L 5 L 6.7 L [mm]	96:300 125:300 150:300 150:400			
Dimensions of sterilizable unit for autoclaving w x h [mm]	307–440 x 507–607			
Footprint w x d [mm]	512 x 679–723			
Ports (vessel lid) 2 L 3.7 L 5 L 6.7 L	15 18 19 19 DN04 connection tubes: 6 5 5 5 DN12 lid ports: 8 12 12 12 DN19 lid ports: 0 0 1 1 Agitator port: 1 1 1 1			
Vessel	Single wall vessel		Single wall vessel	Double wall vessel
Controllers	Agitator speed, temperature, pH, DO	Agitator speed, temperature, pH, DO, foam	Agitator speed, temperature, pH, DO	Agitator speed, temperature, pH, DO, level
Drive	Top drive mechanical seal, 20–1500 rpm			
Agitators	2 flat-blade disc agitator		1 propeller agitator	
Temperature control	Electrical heating jacket and cooling finger with solenoid valve for temperature control	Heating and cooling by perfused stainless steel baffles connected to heating circuit with circulation pump, electrical heater and cooling water valve for temperature control	Electrical heating jacket and cooling finger with solenoid valve for temperature control	Heating circuit connected to double wall; with circulation pump, electrical heater and cooling water valve
Aeration	Ring sparger, 1 pulsed gas line (Air), condenser		Sinter sparger, 3 pulsed gas lines (Air, O ₂ , CO ₂), condenser	
Pumps	2 fixed speed	2 fixed speed, 1 variable	2 fixed speed	2 fixed speed, 1 variable
Dosing	2x bottle, immersion tube, cap and filter	3x bottle, immersion tube, cap and filter	2x bottle, immersion tube, cap and filter	3x bottle, immersion tube, cap and filter
Sampling/harvest	Sampling system with glass tube			
Configurable ports for external devices	1x RS232, 4x analog input with controllers, freely configurable; 1x digital input; 4x analog output; 1x digital output; 1 USB connection			
Software/control	BioSCADA RALF			

Configurations and specifications

Module options

- Minimal equipment
- Option
- Not possible

Vessel		RALF Basic		RALF Advanced	
		2 L Microbial	3.7 L Cell	5 L Microbial	6.7 L Cell
Single wall vessel	Autoclavable benchtop fermentor Single wall glass vessel with rounded bottom Stainless steel lid with DN12 lid ports and DN04 connection tubes Blind plugs DN12 Diaphragm port for inoculation	•	•	•	◦
Double wall vessel	Autoclavable benchtop fermentor Double wall glass vessel with rounded bottom Stainless steel lid with DN12 lid ports and DN04 connection tubes Blind plugs DN12 Diaphragm port for inoculation	-	-	◦	•
Baffles	4 baffles, stainless steel	•	◦	•	◦
Direct drive with mechanical seal	Direct drive from top by brushless DC motor, with mechanical seal, 20–1500 rpm controlled speed	•	•	•	•
Drive, magnetically coupled	Direct drive from top by brushless DC motor, magnetically coupled, 20–1500 rpm controlled speed	◦	◦	◦	◦
Flat-blade disc agitator	2 flat-blade disc agitator, 6-blade, for radial mixing	•	◦	•	◦
Propeller agitator	1 propeller agitator, for axial mixing	◦	•	◦	•
Segment pitched blade agitator	1 segment pitched blade agitator, for axial mixing	◦	◦	◦	◦

Temperature control		RALF Basic		RALF Advanced	
		2 L Microbial	3.7 L Cell	5 L Microbial	6.7 L Cell
Heating pad and cooling finger	Electrical heating jacket and cooling finger with solenoid valve for temperature control	•	•	-	-
Heating circuit connected to perfused baffles	Heating and cooling by perfused stainless steel baffles connected to heating circuit with circulation pump, electrical heater and cooling water valve for temperature control	-	-	•	◦
Heating circuit connected to double wall of vessel	Heating circuit with circulation pump, electrical heater and cooling water valve for temperature control	-	-	◦	•

Aeration		RALF Basic		RALF Advanced	
		2 L	3.7 L	5 L	6.7 L
		Microbial	Cell	Microbial	Cell
Aeration tube	Submerged aeration with sterile filter and check valve. The inlet gas is led to agitator blades for efficient dispersion of bubbles	◦	-	◦	-
Ring sparger	Submerged aeration with sterile filter and check valve. Aeration tube with ring sparger for efficient and careful submerged aeration	•	◦	•	◦
Sinter sparger	Submerged aeration with sterile filter and check valve. Aeration tube with sinter-metal microsparger for efficient submerged aeration also with low gas flow	◦	•	◦	•
MO gas supply: 1 gas supply line (gas 1)	1-channel gas supply unit. Pressure control valve, pressure gauge, rotameter for gas flow indication up to 2 vvm Air, needle valve and pulsed solenoid valve	•	◦	•	◦
CE gas supply: 3 gas supply lines (gases 1, 2 and 3)	3-channel gas supply and mixing unit. Each channel with pressure control valve, pressure gauge, rotameter for gas flow indication up to 0.1 / 0.1 / 0.05 vvm Air / O ₂ / CO ₂ , needle valve and pulsed solenoid valve	◦	•	◦	•
Freely configurable gas lines	1-6 gas lines can be individually configured for submerged or surface aeration and the following gases: Air, O ₂ , CO ₂ , N ₂	◦	◦	◦	◦
MFC instead of pulsed valve for gas lines	Each gas line can be individually equipped with a thermal mass flow controller to measure and control the air flow	◦	◦	◦	◦
Non-standard flow rates for gas lines	For each gas line the flow rate can be freely configured. Selection is possible between the following maximum flow rates: 2, 5, 8, 16, 40, 100, 250 or 500 L/h	◦	◦	◦	◦
Exhaust gas line, condenser	Ventilation via water cooled glass condenser and subsequent sterile filter. Adjustable water flow	•	•	•	•

Addition/Transfer		RALF Basic		RALF Advanced	
		2 L	3.7 L	5 L	6.7 L
		Microbial	Cell	Microbial	Cell
Immersion tube, height adjustable	Height adjustable immersion tube, stainless steel. DN06, for separate harvest	◦	◦	◦	◦
Rotor filter package 20 µm	Open rotor filter with stainless steel sieve 20 µm pore size, mounted on agitator shaft. Incl. foam/level probe with controller, immersion tube and GL45 bottle cap with sterile filter for cell free harvest	-	◦	-	◦
Primary pump module 2x fixed speed	Pump module with 2 fixed speed peristaltic pumps, 130 rpm. Incl. 2 sets of hoses (Di 3.5 mm) and 2 hose clamps	•	•	◦	◦
Primary pump module 2x fixed, 1x variable speed	Pump module with 2 fixed speed peristaltic pumps, 130 rpm and 1 variable speed reversible peristaltic pump, 0-130 rpm. Incl. 3 sets of hoses (Di 3.5 mm) and 3 hose clamps	◦	◦	•	•
Secondary pump module 2x fixed speed	Additional pump module with 2 fixed speed peristaltic pumps, 130 rpm. 2 sets of hoses, 2 hose clamps	◦	◦	◦	◦
Secondary pump module 2x fixed, 1x variable speed	Additional pump module with 2 fixed speed peristaltic pumps, 130 rpm and 1 variable speed reversible peristaltic pump, 0-130 rpm. Incl. 3 sets of hoses (Di 3.5 mm) and 3 hose clamps	◦	◦	◦	◦
Additional pump	Additional stand-alone peristaltic pump with local and remote display and speed control, 1-100 rpm	◦	◦	◦	◦
	Additional stand-alone peristaltic pump with local and remote display and speed control, 0.1-10 rpm	◦	◦	◦	◦
	Additional stand-alone peristaltic pump with local and remote display and speed control, 0.03-3 rpm	◦	◦	◦	◦

		2 L	3.7 L	5 L	6.7 L	2 L	3.7 L	5 L	6.7 L
		Microbial			Cell	Microbial			Cell
Bottles incl. caps and filters, with mounting bracket	2 autoclavable glass bottles 250 mL, incl. GL45 screw cap with sterile filter and immersion tube, incl. mounting brackets to attach bottle to vessel	•			•	◦			◦
Bottles incl. caps and filters, with mounting bracket	3 autoclavable glass bottles 250 mL, each with GL45 screw cap and sterile filter, incl. mounting brackets to attach bottles to vessel	◦			◦	•			•
Sampling system	Sampling system with glass tube for hygienic sampling, incl. mounting bracket, incl. sampling tube stainless steel D; 3.5 mm. Autoclavable	•			•	•			•

Control unit		RALF Basic				RALF Advanced			
		2 L	3.7 L	5 L	6.7 L	2 L	3.7 L	5 L	6.7 L
		Microbial			Cell	Microbial			Cell
Agitation speed control	Measurement and control of agitation speed within 20–1500 rpm	•			•	•			•
Temperature control	Autoclavable temperature probe (Pt100) and temperature controller activating actuators of heating/cooling system	•			•	•			•
pH control	Autoclavable pH probe and pH controller activating actuators (base and acid pump, CO ₂ valves)	•			•	•			•
DO control	Autoclavable DO (pO ₂) probe with DO controller activating actuators and secondary controllers by configurable cascade control	•			•	•			•
Foam/level control	Conductive foam/level probe with controller activating dosing or harvest pumps	◦			◦	•			•
I/O package with additional interfaces and controllers	Package consisting of: - 1x RS232 input, to universal PID controller - 4x 4–20 mA input, to universal PID controller - 1x USB connection - 4x 4–20 mA outputs, freely configurable - 1x digital output 24 V All inputs and outputs are available on sockets at the control cabinet housing	•			•	•			•
BioSCADA RALF software package; installed, ready to use, if bought together with PC	1 system for up to 6 RALF. Runs with Windows system software. Without PC. Customized main operation screen for system visualization and control. Input of setpoints, process values, PID parameters for controllers. Trends and historic process data visualization with scalable timeframe. Display of calculated consumption rates of actuators. Programming of cascades and profiles. Calibration of inputs and outputs. Alarm management, event list. Batch processing. Programming of recipes; step sequence program	•			•	•			•
PC (laptop)	With installed BioSCADA RALF	◦			◦	◦			◦
Power supply: Europe, Asia	1x 230 V, 50/60 Hz	•			•	•			•
Power supply: parts of America	1x 110 V, 50/60 Hz	◦			◦	◦			◦

Vessel kits

- Minimal selection
- Possible optional selection
- Not possible

Spare vessel kit configurator.

An additional autoclavable vessel unit – either single or double wall – for an existing RALF fermentor system can be chosen and configured with the table below. For the RALF Basic only a single wall vessel can be chosen.

Single wall vessel kit	RALF Basic				RALF Advanced				Order no.
	2 L	3.7 L	5 L	6.7 L	2 L	3.7 L	5 L	6.7 L	
Spare vessel kit single wall, autoclavable, minimal package. Incl. glass vessel with lid and blind plugs, bearing and shaft, sampling/harvest tube, temperature probe (Pt100), condenser with hoses and connection pieces, inlet and outlet gas filter with hoses, check valve, cooling device (RALF Basic: finger, RALF Advanced: perfused baffles)									
Single wall vessel kit	•	-	-	-	-	-	-	-	58207
Single wall vessel kit	-	•	-	-	-	-	-	-	58208
Single wall vessel kit	-	-	•	-	-	-	-	-	62090
Single wall vessel kit	-	-	-	•	-	-	-	-	62091
Single wall vessel kit	-	-	-	-	•	-	-	-	58211
Single wall vessel kit	-	-	-	-	-	•	-	-	58212
Single wall vessel kit	-	-	-	-	-	-	•	-	62092
Single wall vessel kit	-	-	-	-	-	-	-	•	62093

Double wall vessel kit	RALF Basic				RALF Advanced				Order no.
	2 L	3.7 L	5 L	6.7 L	2 L	3.7 L	5 L	6.7 L	
Spare vessel kit double wall, autoclavable, minimal package. Incl. glass vessel with lid and blind plugs, bearing and shaft, sampling/harvest tube, temperature probe (Pt100), condenser with hoses and connection pieces, inlet and outlet gas filter with hoses, check valve									
Double wall vessel kit	-	-	-	-	•	-	-	-	58215
Double wall vessel kit	-	-	-	-	-	•	-	-	58216
Double wall vessel kit	-	-	-	-	-	-	•	-	62094
Double wall vessel kit	-	-	-	-	-	-	-	•	62095

Additional options to vessel kits	RALF Basic				RALF Advanced				Order no.
	2 L	3.7 L	5 L	6.7 L	2 L	3.7 L	5 L	6.7 L	
Baffles, 4 pcs. (RALF Advanced: only with double wall vessel)	◦	-	-	-	◦	-	-	-	33923
Baffles, 4 pcs. (RALF Advanced: only with double wall vessel)	-	◦	-	-	-	◦	-	-	33905
Baffles, 4 pcs. (RALF Advanced: only with double wall vessel)	-	-	◦	-	-	-	◦	-	23249
Baffles, 4 pcs. (RALF Advanced: only with double wall vessel)	-	-	-	◦	-	-	-	◦	22771
Flat-blade disc agitator, 6-blade, for radial mixing (D ₀ 40 mm) (2 pcs. recommended for microbial culture)	◦	-	-	-	◦	-	-	-	30209
Flat-blade disc agitator, 6-blade, for radial mixing (D ₀ 48 mm) (2 pcs. recommended for microbial culture)	-	◦	-	-	-	◦	-	-	30288
Flat-blade disc agitator, 6-blade, for radial mixing (D ₀ 60 mm) (2 pcs. recommended for microbial culture)	-	-	◦	◦	-	-	◦	◦	30347
Propeller agitator, for axial mixing (D ₀ 48 mm)	◦	-	-	-	◦	-	-	-	30712
Propeller agitator, for axial mixing (D ₀ 66 mm)	-	◦	◦	◦	-	◦	◦	◦	30713
Segment pitched blade agitator, for axial mixing (D ₀ 48 mm)	◦	-	-	-	◦	-	-	-	112862
Segment pitched blade agitator, for axial mixing (D ₀ 66 mm)	-	◦	◦	◦	-	◦	◦	◦	112861

Aeration	RALF Basic				RALF Advanced				Order no.
	2 L	3.7 L	5 L	6.7 L	2 L	3.7 L	5 L	6.7 L	
Aeration tube	o	o	o	-	o	o	o	-	34475.2
Aeration tube	-	-	-	o	-	-	-	o	34475.1
Ring sparger	o	-	-	-	o	-	-	-	34477
Ring sparger	-	o	o	-	-	o	o	-	34489.1
Ring sparger	-	-	-	o	-	-	-	o	34489.2
Sinter-metal microsparger	o	-	-	-	o	-	-	-	34474
Sinter-metal microsparger	-	o	-	-	-	o	-	-	34488
Sinter-metal microsparger	-	-	o	-	-	-	o	-	34494.1
Sinter-metal microsparger	-	-	-	o	-	-	-	o	34494.2

Addition/Transfer	RALF Basic				RALF Advanced				Order no.
	2 L	3.7 L	5 L	6.7 L	2 L	3.7 L	5 L	6.7 L	
Immersion tube, height adjustable	o	o	o	o	o	o	o	o	58219
Open rotor filter with stainless steel sieve 20 µm pore size, sieve length 127 mm, mounted on agitator shaft. Immersion tube for cell free harvest. (For 2 L vessels not possible in combination with heating circuit via perfused baffles. Availability of lid ports has to be checked)	o	o	o	-	o	o	o	-	58220
Open rotor filter with stainless steel sieve 20 µm pore size, sieve length 222 mm, mounted on agitator shaft. Immersion tube for cell free harvest.	-	-	-	o	-	-	-	o	58221
Autoclavable glass bottle 250 mL, incl. GL45 screw cap with sterile filter and immersion tube, incl. mounting bracket to attach bottle to vessel. Incl. hoses	o	o	o	o	o	o	o	o	58222
Sampling system with glass tube for hygienic sampling, incl. mounting bracket. Autoclavable	o	o	o	o	o	o	o	o	34979

Control unit	RALF Basic				RALF Advanced				Order no.
	2 L	3.7 L	5 L	6.7 L	2 L	3.7 L	5 L	6.7 L	
Autoclavable pH probe, short	o	o	o	-	o	o	o	-	64474
Autoclavable pH probe, long	-	-	-	o	-	-	-	o	64475
Autoclavable DO (pO ₂) probe, nominal length 200 mm (without transmitter)	o	o	o	-	o	o	o	-	64476
Autoclavable DO (pO ₂) probe, nominal length 300 mm (without transmitter)	-	-	-	o	-	-	-	o	64477
Head transmitter for pH and DO probes	o	o	o	o	o	o	o	o	64086
Conductive foam/level probe, length 254 mm. (RALF Basic: only functional if existing control system already includes transmitter and controller). (Can be used to control foam or level, not both together. Also necessary for level control together with rotor filter)	o	o	o	-	o	o	o	-	30275.2
Conductive foam/level probe, length 354 mm. (RALF Basic: only functional if existing control system already includes transmitter and controller). (Can be used to control foam or level, not both together. Also necessary for level control together with rotor filter)	-	-	-	o	-	-	-	o	30275.3

Technical data

General	2 L	3.7 L	5 L	6.7 L
Ambient temperature [°C]	5–40			
Relative humidity (non-condensing) [%]	85			
Operating temperature (cultivation) [°C]	Max. 80			
Operating temperature (sterilization in autoclave) [°C]	Max. 130			
Operating pressure (sterilization in autoclave) [barg psig]	Max. 1.5 21			
Net weight RALF Basic [kg lbs]	73 161.0	74 163.1	75 165.4	76 167.6
Gross weight RALF Basic wrapped [kg lbs]	96 211.7	97 213.9	98 216.1	99 218.3
Net weight RALF Advanced [kg lbs]	82 180.8	83 183.0	84 185.2	85 187.4
Gross weight RALF Advanced wrapped [kg lbs]	105 231.5	106 233.7	107 235.9	108 238.1
Weight autoclavable unit (empty) [kg lbs]	17 37.5	19 41.9	21 46.3	23 50.7

Utility requirements

Power supply	CEE 7/7, 1x 230 V (110 V to 264 V), 50/60 Hz, 10 A fused NEMA 5–12, 1x 110 V, 50/60 Hz, 16 A fused			
Max. power consumption (230V) (110 V) [W]	1400 800 or 1400 (depending on heater type)			
Cooling water supply: connection flow pressure	Hose nipples 6/1 mm 2–4 L/min 0.6–2 bar (8.7–29.0 psig)			
Cooling water return: connection flow pressure	Hose nipples 6/1 mm 2–4 L/min pressureless			
Peak water consumption during cooling at 2 bar, with exhaust cooler [L/h]	Max. 250			
Average water consumption during cultivation mode [L/h]	Approx. 60			
Gas (dry, particle- and oil-free): connection flow pressure	Pneumatic plug connection 8/1 mm 2–500 L/h 2.5–10 barg (36.3–145.0 psig)			
Gas consumption	Depending on process parameters			

Vessel	2 L	3.7 L	5 L	6.7 L
Recommended working volume [L], max.	1.3	2.5	3.3	4.5
Recommended working volume [L], min.	0.65	0.9	1.2	1.2

Lid process connections

DN04 connection tubes	6	5	5	5
DN12 lid ports	8	12	12	12
DN19 lid ports	-	-	1	1
Agitator port	1	1	1	1

Motor type

BLDC

Motor torque [Nm]	1.6
Motor power [W]	230

Agitator diameter, standard [mm]

Flat-blade disc agitator (2x)	40	48	60	60
Propeller agitator (1x)	48	66	66	66
Segment pitched blade agitator (1x)	48	66	66	66

Material vessel (in contact with medium)	Borosilicate glass
Material steel parts (in contact with medium)	316L
Steel parts surface roughness (in contact with medium) [µm]	Ra 0.8
Material polymer (in contact with medium)	EPDM, PTFE, silicone

Temperature control	2 L	3.7 L	5 L	6.7 L
Temperature control range with cooling water (chilled) [°C]				4–80
Double jacketed vessel: electrical heater [W]				800*
Single wall vessel: heating blankets [W]	300*	400*	400*	500*
Heating-up time	Approx. 1 min/°C			
Max. cooling-down time from 60 to 25 °C (at 15 °C cooling water temperature, double wall, 500 rpm agitator speed, no aeration) [min]	50	50	50	50

* only with 208V-230V power supply

Requirements for external chiller

Cooling water supply: connection pressure	Hose to nipples 6/1 mm 0.6–2 bar (8.7–29.0 psig)		
Cooling water return: connection pressure	Hose to nipples 6/1 mm pressureless		
Cooling capacity up to 3 RALF up to 6 RALF	400 W, 30 L water tank capacity 600 W, 50 L water tank capacity		

Aeration	2 L	3.7 L	5 L	6.7 L
Rotameter Air for microbial cultivation [Ln/h] *	0–250	0–250	0–500	0–500
Rotameter Air O ₂ CO ₂ for cell cultivation [Ln/h] *	0–8 8 5	0–16 16 8	0–16 16 8	0–40 40 8
Rotameter N ₂ [Ln/h] *	0–100	0–100	0–250	0–250
Mass flow controller Air for microbial cultivation [Ln/h] *	0–250 [±1.0%, 1:50]		0–500 [±1.0%, 1:50]	
Mass flow controller Air O ₂ CO ₂ for cell cultivation [Ln/h] *	0–8 8 5 [±1.0%, 1:50]	0–16 16 8 [±1.0%, 1:50]	0–16 16 8 [±1.0%, 1:50]	0–40 40 8 [±1.0%, 1:50]
Mass flow controller N ₂ [Ln/h] *	0–100 [±1.0%, 1:50]		0–250 [±1.0%, 1:50]	
Inlet filter and outlet filter	0.2 µm pore size			

* Other maximal flow rates available for each gas line: 2, 5, 8, 16, 40, 100, 250 or 500 Ln/min

Addition/Transfer	2 L	3.7 L	5 L	6.7 L
Peristaltic pumps				
Pump head	BioE/Oina			
Fixed rpm flow rate hose D _i 2.0 mm flow rate hose D _i 3.5 mm	130 rpm 35 mL/min 60 mL/min			
Variable rpm flow rate hose D _i 2.0 mm flow rate hose D _i 3.5 mm	0–130 rpm 0–35 mL/min 0–60 mL/min			
Storage bottles, volume [mL]	250			

Control unit	2 L	3.7 L	5 L	6.7 L
Communication to PC	RJ45 (TCP/IP)			
Agitator speed [rpm]	20–1500			
Temperature [°C]	0–150 ± 0.1			
pH, gel electrode [pH]	2–12 ± 0.05			
DO, optical	4 ppb to saturation ± [1% + 4 ppb]			
Foam and level, conductive on / off	On/off, reaction time			
Free I/Os: RS232 in USB in 4–20 mA in 4–20 mA out 24 V out	1 1 4 4 1			

Minimum requirements for external PC

Processor RAM HD ports OS	PIII, 1.2 GHz 512 MB 20 GB USB 2.0 Windows XP, 7, 8.1, 10			
Screen	Min. 15" color			

Material tower

Stainless steel AISI 304 + steel 37, varnished

Dimensions

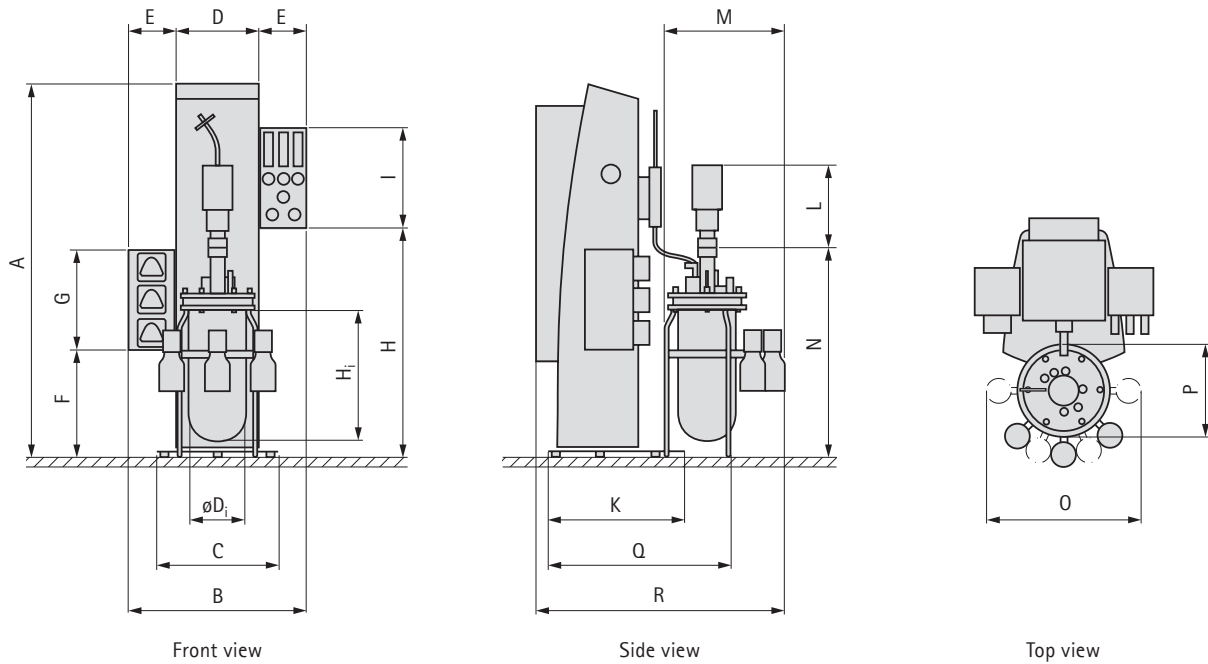

A [mm]	B [mm]	C [mm]	D [mm]	E [mm]	F [mm]	G [mm]	H [mm]	I [mm]	K [mm]	L [mm]
1065	512	342	240	136	309	285	652	285	390	246

M* [mm]	N* [mm]	O* [mm]	P [mm]	Q [mm]	R [mm]	Di [mm]	Hi [mm]	
RALF 2L	307	507	400	222	489	679	96	300
RALF 3.7L	325	509	417	239	502	690	125	300
RALF 5L	349	607	440	264	521	721	150	300
RALF 6.7L	349	607	440	264	521	723	150	400

A [inch]	B [inch]	C [inch]	D [inch]	E [inch]	F [inch]	G [inch]	H [inch]	I [inch]	K [inch]	L [inch]
41.93	20.16	13.46	9.45	5.35	12.17	11.22	25.67	11.22	15.35	9.69

M* [inch]	N* [inch]	O* [inch]	P [inch]	Q [inch]	R [inch]	Di [inch]	Hi [inch]	
RALF 2L	12.09	19.96	15.75	8.74	19.25	26.73	3.78	11.81
RALF 3.7L	12.80	20.04	16.42	9.41	19.76	27.17	4.92	11.81
RALF 5L	13.74	23.89	17.32	10.39	20.51	28.38	5.90	11.81
RALF 6.7L	13.74	23.89	17.32	10.39	20.51	28.46	5.91	15.75

* Maximum dimension for autoclaving

Arrangement type 1

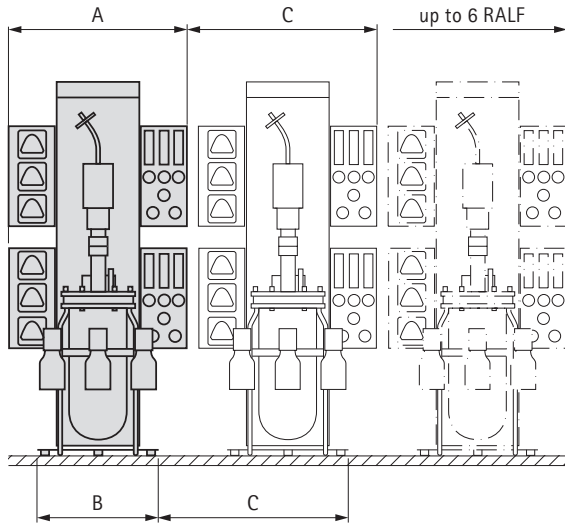

Arrangement type 2

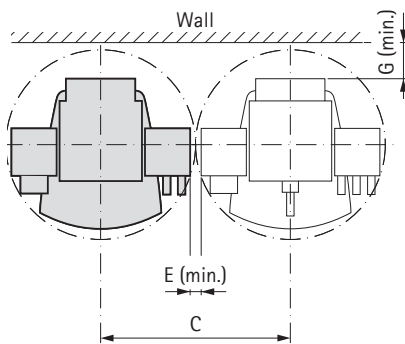
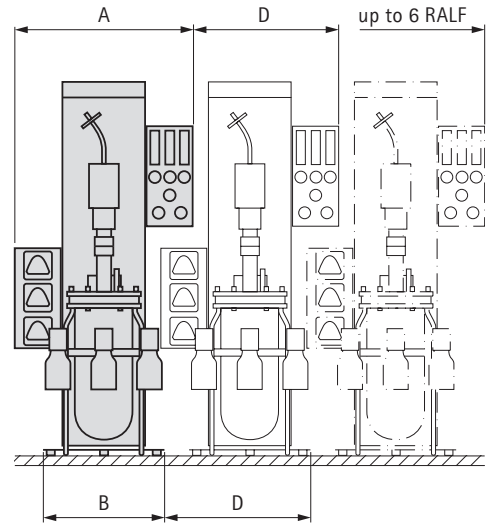

Top view (Arrangement type 1)

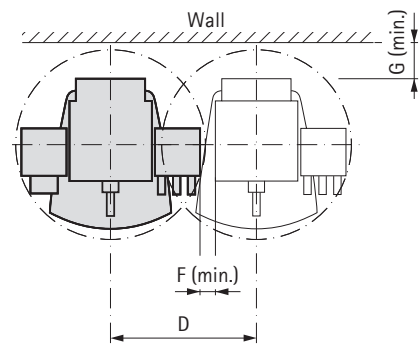

Top view (installation type 2)

A [mm]	B [mm]	C [mm]	D [mm]	E* [mm]	F* [mm]	G* [mm]
512	342	550	426	35	50	130

A [inch]	B [inch]	C [inch]	D [inch]	E* [inch]	F* [inch]	G* [inch]
20.157	13.464	21.653	16.771	1.378	1.968	5.118

* Minimum dimension for maintenance